



# Pressurized Filter

## Up to 1250 gallons

ITEM #FP1250UV

**REMINDER**  
**CALL 1-888-755-6750**  
**BEFORE RETURNING TO STORE.**



**Questions, problems, missing parts?** Before returning to your retailer, call our customer service department at 1-888-755-6750, 8 a.m.-6 p.m., EST, Monday-Friday, or email us at [customer@thepondboss.net](mailto:customer@thepondboss.net). Or visit our website [www.thepondboss.net](http://www.thepondboss.net).

### PACKAGE CONTENTS

Part	Description	Quantity
A	Tank with UV clarifier	1
B	O-ring	1
C	Cover	1
D	Lid	1
E	Bio media balls	12
F	Coarse filter	1
G	Fine filter	1
H	Adapter	2
I	Gasket	2
J	Locking ring	2
K	Small adapter	1
L	Small gasket	1

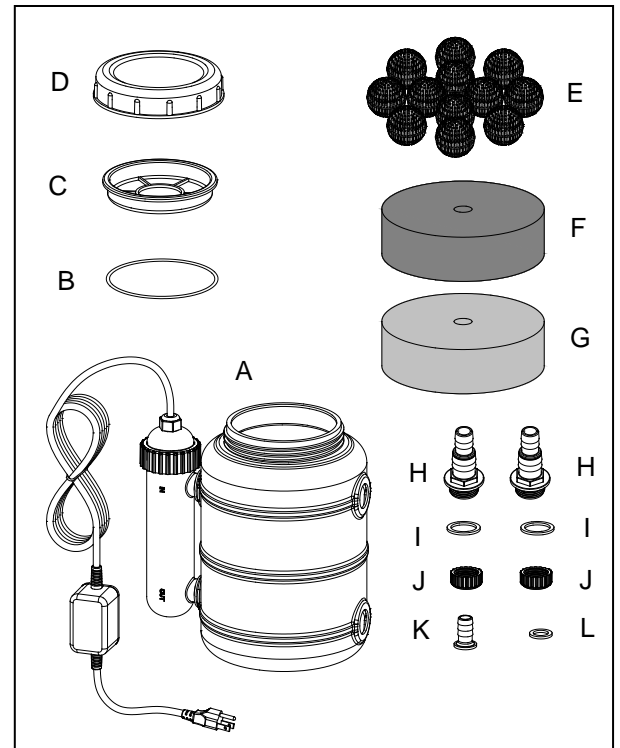

### WARNINGS AND CAUTIONS

#### WARNING

- **DO NOT SUBMERGE THE LIGHT ASSEMBLY.**
- **WARNING** – Improper connection of the appliance-grounding conductor can result in a risk of electric shock. Check with a qualified electrician or service representative if you are in doubt whether the appliance is properly grounded. Do not modify the plug provided with the appliance; if it will not fit the outlet, have a proper outlet installed by a qualified technician.
- If the appliance falls into water, **DO NOT** reach for it! First, unplug it and then retrieve it. If electrical components of the appliance get wet, unplug the appliance immediately.
- Do not operate any appliance if it has a damaged cord or plug, or if it is malfunctioning or if it is damaged in any manner.
- Always unplug the appliance from the outlet before putting on or taking off parts, before cleaning or when not in use.
- Connect only to a circuit that is protected by a ground-fault circuit-interrupter (GFCI).
- Risk of Electric Shock - Do not use the UV filter if the quartz tubing around the lamp is broken. Immediately unplug and seek an authorized repair service or discard the unit.



**PLEASE CALL 1-888-755-6750 BEFORE RETURNING TO THE STORE.**  
**WWW.THEPONDBOSS.NET**

- **GROUNDING INSTRUCTIONS** – This appliance must be grounded. In the event of a malfunction or breakdown, grounding will reduce the risk of electric shock by providing a path of least resistance for electric current. This appliance is equipped with a cord having an appliance-grounding conductor and a grounding plug. The plug must be plugged into an appropriate outlet that is installed and grounded in accordance with all local codes and ordinances.

**CAUTION**

- UV light may cause irritation to the skin and/or eyes. Avoid exposure.
- **DANGER – ULTRAVIOLET RADIATION** – Disconnect Power Before Replacing Lamp.
- Prolonged or repeated exposure to UV light may have adverse physical effects including, severe damage to your skin and eyes. Seek immediate medical attention for overexposure to UV radiation.
- Keep the cord away from high temperatures or other heat sources.
- Do not lift the light or the transformer by its power cord.
- This light assembly has not been investigated for use in swimming pools or hot tubs.

**IMPORTANT NOTES**

---

- This product is designed to prohibit its operation unless it is fully assembled with the lamp base screwed completely into the housing.
- UV rays are harmful to your eyes and skin.
- Do not attempt to operate this product unless the lamp is completely assembled within the light housing.
- This product conforms to the Code of Federal Regulations (CFR) requirements including, Title 21, Chapter 1, Subchapter J, Radiological Health.

<b>Specifications</b>	
Lamp Voltage	60V
Lamp Current	0.2A
Lamp Power	9 W
Rated Frequency	60 Hz
UV Irradiance	35 $\mu$ W/cm <sup>2</sup>
Bulb Life	8000 hours
Bulb Model Number	FUV9RB
UV Wave Length	UV(C) · 254 nm

**PREPARATION**

---

Before beginning assembly of product, make sure all parts are present. Compare parts with package contents list and diagram above. If any part is missing or damaged, do not attempt to assemble, install or operate the product. Contact customer service for replacement parts.

- Estimated Assembly Time: 20 minutes
- Tools required for assembly: hacksaw.



**PLEASE CALL 1-888-755-6750 BEFORE RETURNING TO THE STORE.  
WWW.THEPONDBOSS.NET**

## ASSEMBLY INSTRUCTIONS

1. If using 3/4 in. ID tubing, proceed to step 2. If using 1 in. ID tubing, cut the adapter as shown using a hacksaw. Fig. 1

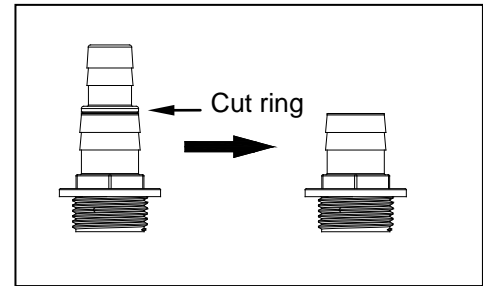

**Fig. 1**

2. Assemble the locking ring, adapter and gasket. Fig. 2

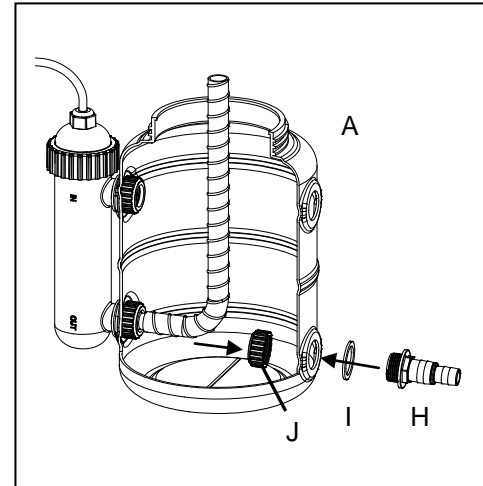

**Fig. 2**

3. Place the bio-balls inside the filter. Fig. 3

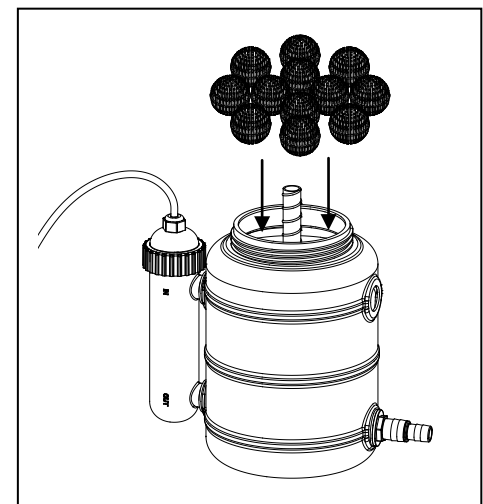

**Fig. 3**



- Place the fine filter pad inside the tank. Then place the coarse filter pad over the fine filter pad. Fig. 4

NOTE: The coarse filter pad is black. The fine filter pad is blue.

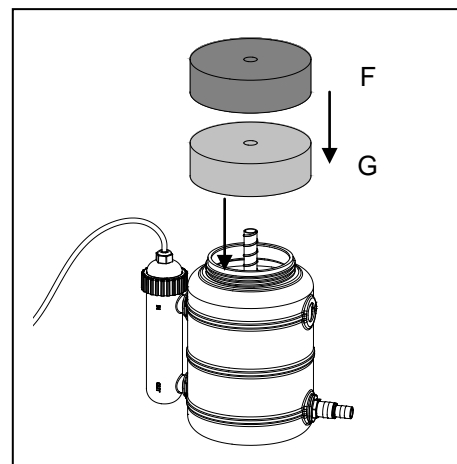

Fig. 4

- Connect the small adapter to the adapter using the locking ring. Be sure to place the gasket between adapter and tank, place the small gasket between the small adapter and adapter. Fig. 5

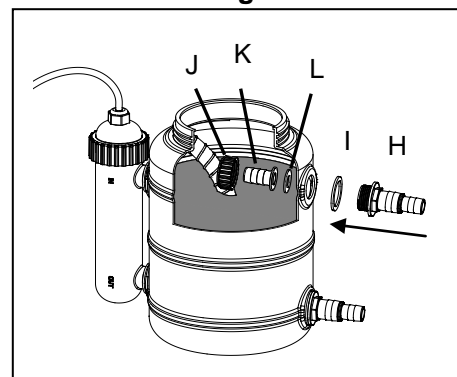

Fig. 5

- Connect tubing to the small adapter. Fig. 6

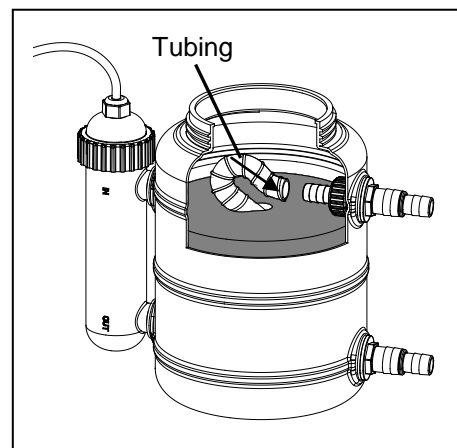

Fig. 6

- Turn over the cover and locate the groove. Place the o-ring into the groove. Notes: o-ring one side is flat, another side is round, must place the flat side down into the groove of cover, otherwise it will cause leakage. (See detail view) Fig. 7

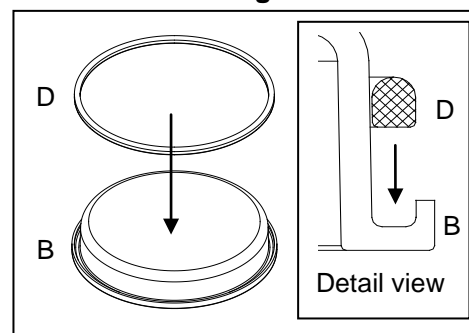
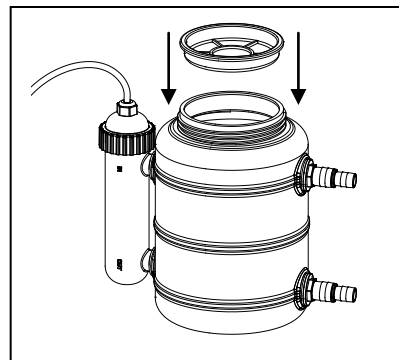

Fig. 7



PLEASE CALL 1-888-755-6750 BEFORE RETURNING TO THE STORE.  
WWW.THEPONDBOSS.NET

8. Place the cover (with the o-ring attached) over the top of the tank.  
Fig. 8



**Fig. 8**

9. Screw the lid onto the top of the tank. Make sure that it is secure, or the filter will leak. Fig. 9

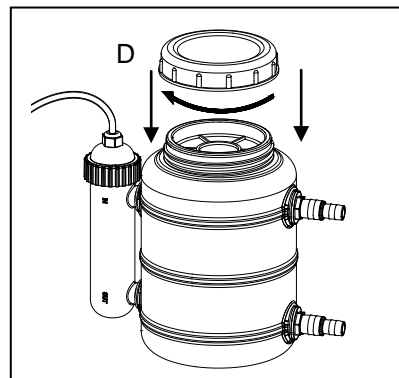

**Fig. 9**

10. Connect the UV clarifier plug into a properly grounded electrical outlet. Fig. 10

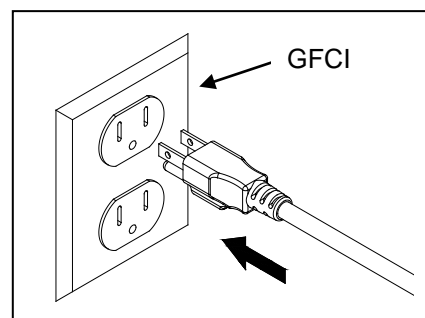

**Fig. 10**

11. Wait several seconds for the light to turn on then check the indicator light to verify if the light is functioning correctly.  
Fig. 11

NOTE: This clarifier has a safety feature that only allows the UV light to turn on if the lamp holder is fully seated into the lamp housing.

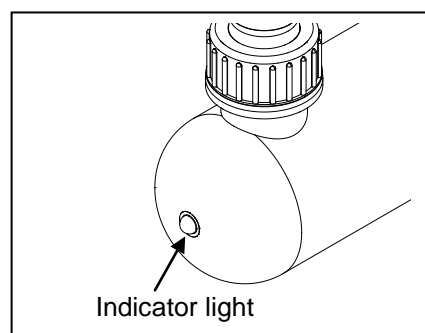

**Fig. 11**



12. Connect a length of tube from the outlet of a pump to the inlet of the filter (upper hole). Connect a length of tubing from the outlet of the filter (lower hole) to a water feature. Fig. 12

NOTE: Pump and tubing is NOT INCLUDED. The adapter is compatible with 1 in. or 3/4 in. tubing.

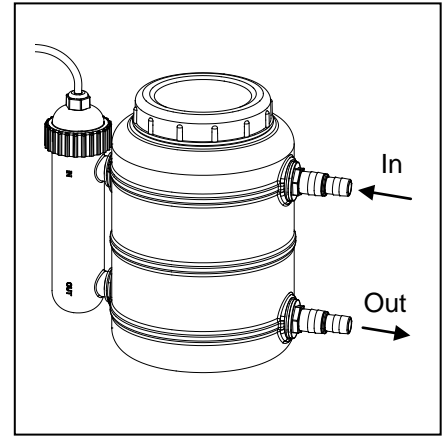

Fig. 12

### ASSEMBLY INSTRUCTIONS – Replacing the bulb

1. Disconnect the UV light from the outlet. Be sure to allow sufficient time for the light to cool before disassembling the light. Fig. 13

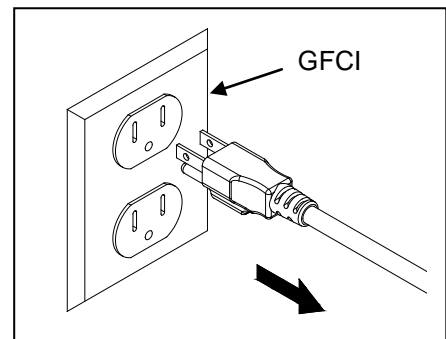

Fig. 13

2. Rotate the locking ring counterclockwise to remove the lamp holder. Fig. 14

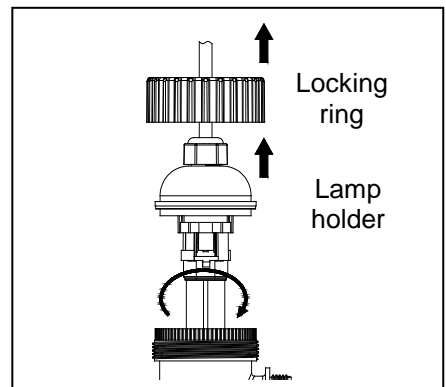

Fig. 14



PLEASE CALL 1-888-755-6750 BEFORE RETURNING TO THE STORE.  
WWW.THEPONDBOSS.NET

- Carefully remove the old bulb by firmly pulling on the base. Carefully install the new bulb. Fig. 15

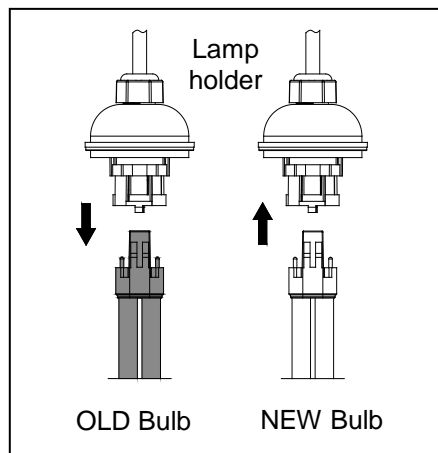

Fig. 15

- Reinstall the lamp holder and locking ring. Fig. 16

NOTE: This clarifier has a safety feature that only allows the UV light to turn on if the lamp holder is fully seated into the lamp housing.

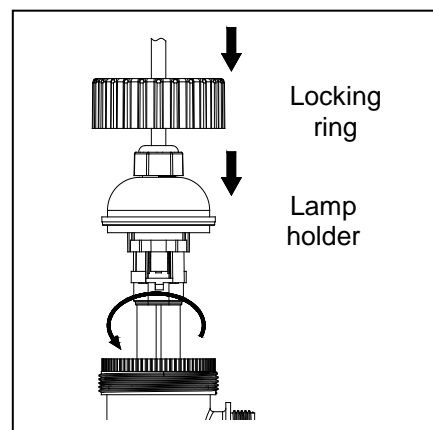

Fig. 16

- Connect the plug into a properly grounded electrical outlet. Fig. 17

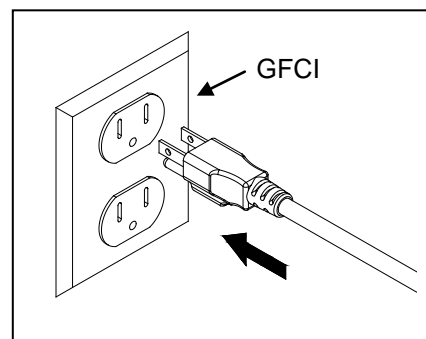

Fig. 17

- Wait several seconds for the light to turn on then check the indicator light to verify if the light is functioning correctly. Fig. 18

NOTE: This clarifier has a safety feature that only allows the UV light to turn on if the lamp holder is fully seated into the lamp housing.

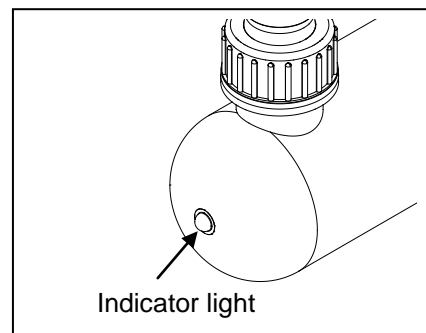

Fig. 18



PLEASE CALL 1-888-755-6750 BEFORE RETURNING TO THE STORE.  
WWW.THEPONDBOSS.NET

## **CARE AND MAINTENANCE – Pressure Filter**

---

- Occasional cleaning of the filter pads will be necessary to ensure the proper functioning of the system. The top filter pad is a coarse pad (black) and will catch larger particles. The bottom filter pad (blue) is a fine pad designed to trap smaller debris. Both pads should be removed and washed with clean water when they are visibly soiled.
- Filter pads should be changed annually. The exterior surface of the filter box may also need occasional cleaning. Do not use any chemicals that may destroy the beneficial bacteria.
- The bio balls in your filter system and the inside surfaces of the filter box contain the beneficial bacteria. At least once a year the entire system should be disassembled and cleaned thoroughly using warm, soapy water (biodegradable soap). This should not be done during the warm season as it may take up to 8 weeks to re-establish the environmental balance. The best time of the year to “breakdown” your system is in early spring before the water temperatures begin to rise. This is also the ideal time to replace the filter pads.

## **CARE AND MAINTENANCE – UV Clarifier**

---

To maximize the performance of the FUV9, periodically disassemble the unit to clean dirt and debris from the exterior of the glass tube.

### **IMPORTANT NOTE:**

Be sure that the entire unit is completely dry and gaskets are properly seated when reassembling the FUV9.

Failure to do so will result in water leakage, which can cause damage to the light unit.

1. Disconnect the UV light from the outlet. Be sure to allow sufficient time for the light to cool before disassembling the light.
2. Unscrew the locking ring, and pull out the light unit.
3. Carefully pull out the glass tube holder by twisting and then pull out.
4. Use warm, soapy water to clean the glass tube. Be sure to use biodegradable soap.
5. Reassemble the FUV9, and be sure that all gaskets and o-rings are seated properly.

## **TROUBLESHOOTING – UV Clarifier**

---

If the light fails to operate:

- Check to make sure the power cord is plugged in and the light is getting power.
- Check to make sure that the lamp holder is screwed completely into the body. (This product is designed to prohibit operation unless it is fully assembled with the lamp holder screwed completely into the body.)
- Check bulb to make sure that it has not burned out. Replace the bulb as necessary, or after every season. Bulbs are available by calling the customer service department.



**PLEASE CALL 1-888-755-6750 BEFORE RETURNING TO THE STORE.  
WWW.THEPONDBOSS.NET**



## REPLACEMENT PARTS LIST

For replacement parts, call our customer service department at 1-888-755-6750, 8 a.m.-6 p.m., EST, Monday-Friday.

Part	Description
B	O-ring
C	Cover
D	Lid
H	Adapter
I	Gasket
J	Locking ring
K	Small adapter
L	Small gasket
M	Tank
N	Lamp housing
O	Lamp holder gasket
P	Bulb holder
Q	Glass tube holder
R	O-ring 1
S	Glass tube gasket
T	Glass tube
U	Glass tube locking nut
V	O-ring 2

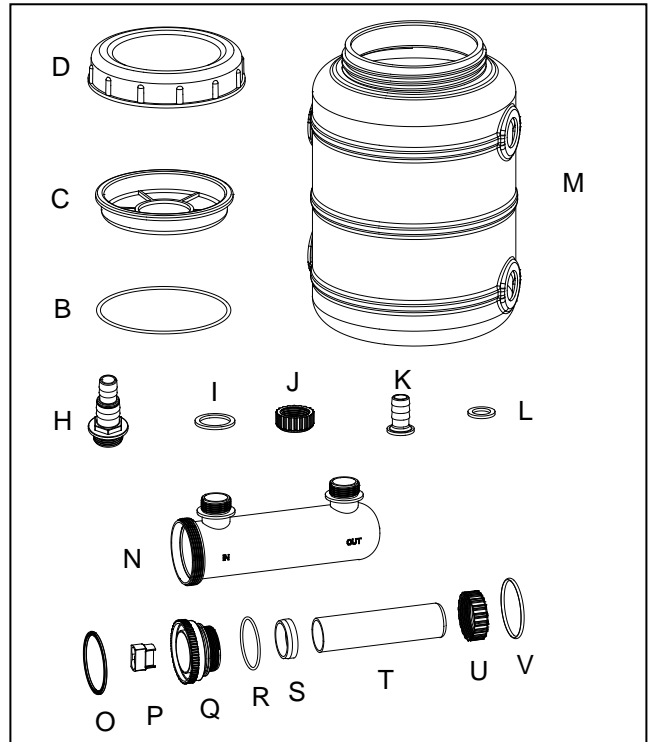

Printed in China



PLEASE CALL 1-888-755-6750 BEFORE RETURNING TO THE STORE.  
WWW.THEPONDBOSS.NET

## LIMITED WARRANTY

---

All pumps and electrical products are warranted to the user against defective material and workmanship, under normal working conditions. This warranty period begins on the date of purchase by the original purchaser.

Unless otherwise specified all pond boss® electrical products are warranted to the user against defective material and workmanship, under normal working conditions for 1 year from the date of purchase.

- Pond and Waterfall pumps are warranted for 3 years.
- All pond boss® liners are warranted to the user against defective workmanship, under normal working conditions for 20 years from the date of purchase.
- All other pond boss® products are warranted to the user against defective material and workmanship, under normal working conditions for 90 days.

### **Application**

Warranty covers only properly installed and maintained units. Any damage to the cord or modification to the unit will invalidate the warranty. Pump warranty is limited to applications pumping fresh water in a pond or fountain only. Other liquid applications or extreme temperature uses must be approved in writing by the manufacturer. Receipt and product date code are required for warranty claims.

### **Warranty Claim**

**Warranty claims must be made by calling customer service (at 1-888-755-6750).** If the item is determined to be defective, you will be given authorization to return the defective part(s), freight pre-paid, along with proof of purchase.

### **Disposition**

The manufacturer will make a good faith effort for prompt disposition regarding all warranty claims. Returned product will be inspected to determine cause of failure before warranty is applied. Warranty does not cover any costs associated with the shipping, handling, installation or removal of products or parts subject to this warranty. For products damaged in transit, a claim should be filed with the carrier.

### **Disclaimer**

Any oral statements made about the product by the seller, the manufacturer, the representatives, or any other parties do not constitute warranties, should not be relied upon by the user, and are not part of the contract for sale. The seller's and manufacturer's only obligation, and buyer's only remedy shall be for the manufacturer to either replace and/or repair at the manufacturer's sole discretion, the product as described above. Neither seller nor the manufacturer shall be liable for injury, loss or damages for lost profits, lost sales, injury to person or property, or any other incidental or consequential loss arising from any cause whatsoever, no matter whether based upon warranty, contract, negligence or other misuse, and the buyer and user agree that no other remedy shall be available to them. Before using, the buyer and user shall determine the suitability of the product for the intended use, and assume all risk and liability whatsoever in connection therewith. The warranty and remedy described in this limited warranty is an exclusive warranty and remedy in lieu of any other warranty or remedy expressed or implied. All other warranties and remedies are hereby expressly excluded, including but not limited to any implied warranty of merchantability of fitness for any particular purpose. This warranty gives the buyer and user specific legal rights, and buyer and user may also have other rights which vary from state to state. Some states do not allow exclusions or limitations of incidental or consequential damages, so the above limitations or exclusions may not apply to you.

**REMINDER**  
**CALL 1-888-755-6750**  
**BEFORE RETURNING TO STORE.**



**PLEASE CALL 1-888-755-6750 BEFORE RETURNING TO THE STORE.**  
**WWW.THEPONDBOSS.NET**